

## 2. MECHANICAL ADJUSTMENTS

- To press the PLAY lever when there is no cassette half in the cassette compartment, first turn ON the cassette half detector switch (micro-switch), and then press the lever while holding down the cassette detector pin.
- Ordinary adjustments will require removal of the mechanical assembly from the main body but without disconnecting the wiring.

### 2.1 PINCH ROLLER COMPRESSION ADJUSTMENT

1. After setting to the play mode, insert 2 tension gauges (spring balances with 500g scales) as shown in Fig. 21, and pull the pinch rollers away slightly (about 0.5mm) from the capstans.
2. Gently ease the pinch rollers back onto the capstans, and read off the value when the pinch rollers first begin to rotate.
3. The measured values should lie in the 30g to 130g range on the supply reel side, and in the 130g to 230g on the take-up reel side.
4. If the measured values lie outside these ranges, replace the relevant pinch compression spring (RBH-373) with a new one, and re-adjust.

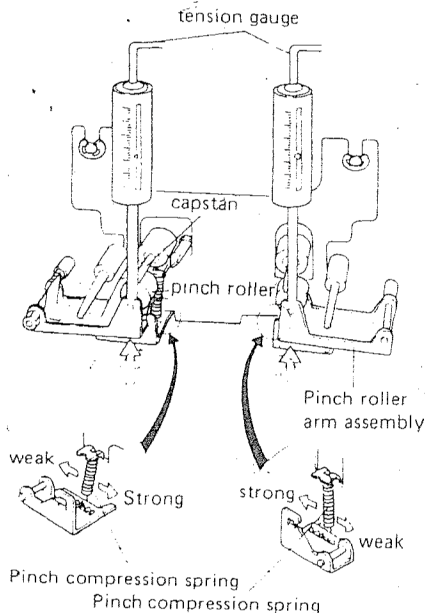

Fig. 21

### 2.2 REEL BASE TORQUE

Reel base torque during play, fast forward, and rewind modes is measured by a torque meter. Allowable torque ranges are tabulated in Table 1. If measured values lie outside these ranges, clean both reel bases and idlers, plus other areas such as the pinch roller contacting surface, and then measure again. If the measured values still lie outside the allowable ranges, replace the supply reel base full assembly (RXA-845) and/or take-up reel base full assembly (RXA-844).

Table 1

Take-up Reel Base	
Play take-up torque	35 ~ 55g
Fast forward take-up torque	75 ~ 130 g.cm
Rewind back tension torque	5 ~ 9 g.cm

Supply Reel Base	
Play back tension torque	4 ~ 8 g.cm
Rewind take-up torque	75 ~ 130 g.cm

### 2.3 TAPE SPEED

1. Connect a frequency counter to the line output terminals.
2. Set the PITCH CONTROL to the center click stop.
3. Playback the 3kHz section of the STD-301 test tape used for checking tape speed and wow and flutter. The frequency at the beginning of the tape should be within 2995 to 3010Hz. If it is not, adjust by means of the semi-fixed volume in the motor control assembly (as shown in Fig. 22).

### 2.4 FAST FORWARD AND REWIND MODE INVERSION

When switching back and forth between fast forward and rewind modes, the rotating direction of the fast forward motor is reversed, and the fast forward idler is inverted. The force applied in this latter operation may be adjusted by regulating the fast forward lever spring as shown in Fig. 23. To increase the force applied, shift the spring across to the left (direction of the arrow).

When making this adjustment, place the assembly in a horizontal position, or tilt the front upwards at an angle of 45°. Shift the fast forward lever spring across (if necessary) so that the fast forward idler will invert smoothly.

- After completing this adjustment, re-check the fast forward/rewind mode inversion operation several times to ensure that there are no abnormal vibrations etc.
- If none of the fast forward lever spring positions is sufficient for normal inversion operation, replace the fast forward lever spring (RBH-368) and fast forward idler full assembly (RXA-581).

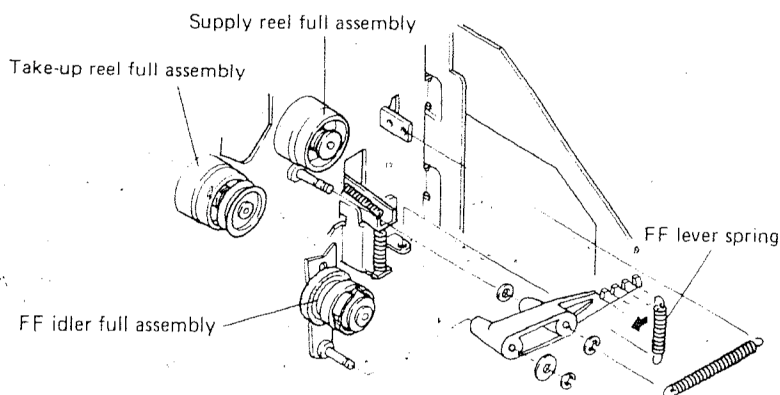

### 2.5 WOW AND FLUTTER

Rotational deviations in the tape transport system of the CT-F1000 high quality cassette deck, have been suppressed to less than 0.05% (WRMS). If any deterioration in this specified rating is found, check the following points, and clean, adjust, or replace as necessary.

1. Capstan curvature, vibration, soiling.
2. Wobble in flywheel thrust.
3. Deterioration or soiling of capstan belts.
4. Pinch roller soiling or compression abnormality.
5. Take-up idler soiling, eccentricity, or compression abnormality.
6. Torque deviations in take-up reel base.
7. Abnormal back-tension values.
8. Torque deviation due to irregular operation of sensing switch or tape counter.
9. Faulty cassette tapes being used.

### 2.6 REPLACEMENT OF MICRO-SWITCHES

There are 3 sets of micro-switches operated (turned ON/OFF) when a cassette half is loaded in the cassette compartment. These include (i) erase prevention switch, (ii) chrome tape detector switch, and (iii) cassette half detector switch. If any of these switches are replaced, check that all new switches function properly when a cassette half is loaded.

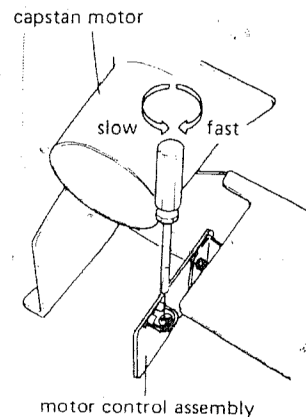

Fig. 22

Fig. 23

### 3. ELECTRICAL ADJUSTMENTS

Prior to commencing any electrical adjustments, first check the items in the following list.

1. Has the adjustment of the mechanical systems been completed?
2. Have the heads, pinch rollers, and capstans been cleaned properly, and have the heads been demagnified by the head eraser?
3. All adjustments should be performed with the designated test tapes.

- STD-331A: for general playback testing.
- STD-341A: for general playback adjustments.
- STD-301: for checking tape speed and wow and flutter.
- STD-601: for general playback and recording adjustments (STD tape).
- STD-602: for general playback and recording adjustments (chrome tapes)

4. The level during measurements is to be set at 0dB = 1V, and a 50 kilohm (47 to 52 kilohm) dummy load connected to the line output terminals.

5. Unless otherwise specified, the front panel switches should be in the following positions:

EQ	STD
BIAS	STD
REC LIMITER	OFF
DOLBY NR	OFF
MPX FILTER	OFF
TEST TONE	OFF
MONITOR	TAPE

- The places to be checked and/or adjusted are shown in the block diagram in Fig. 24.

#### • Check and Adjust Items

It is essential that all items be checked, and adjusted if necessary, in the following order. If the order is changed, adjustments will be incomplete, resulting in a drop in performance.

#### Playback

1. Head azimuth
2. Playback equalizer
3. Playback level

#### Recording

4. 0dB of level meters
5. Bias trap
6. Recording bias
7. Recording and playback frequency response
8. Recording level

#### Dolby Circuit

9. Playback Dolby
10. Recording Dolby

#### Checking other functions

11. Operation of peak indicator
12. Limiter
13. Dolby Rec Cal

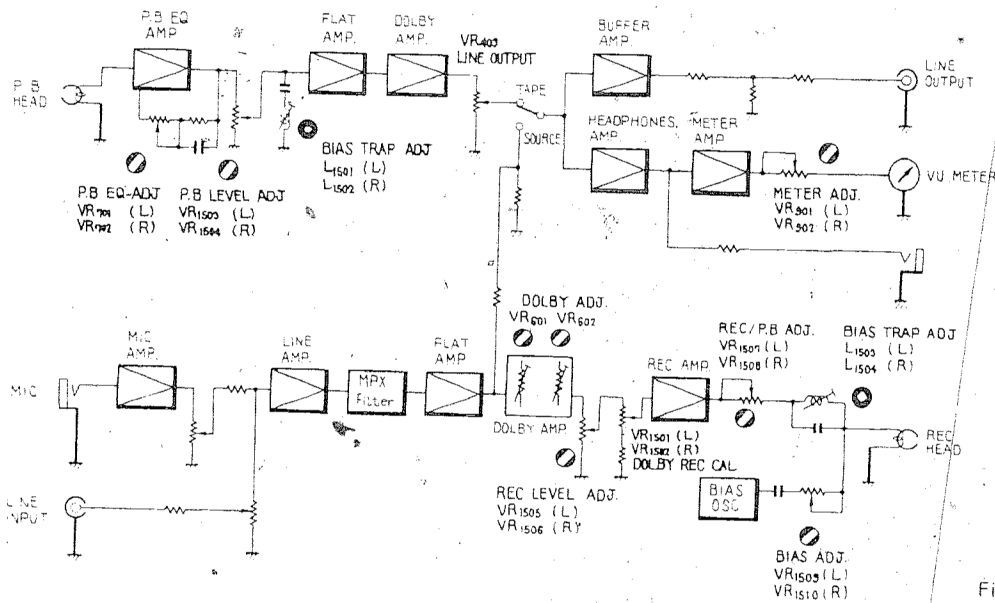

Fig. 24

### 3.1 HEAD AZIMUTH

1. Connect a millivoltmeter to T.P. terminal No.54 (L. ch) of the main board, and another millivoltmeter to T.P. No.55 (R. ch). Also connect both millivoltmeters to ground, as shown in Fig. 26.
2. Playback the 10kHz, -20dB section of test tape STD-341A, and adjust the head azimuth adjustment screw A (see Fig. 25) to produce maximum output level in both L and R channels.

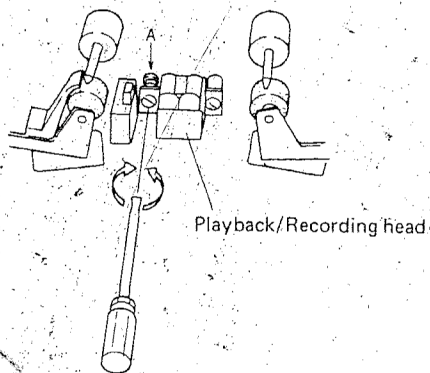

Fig. 25

### 3.3 PLAYBACK LEVEL

1. Leave the millivoltmeter connected to the same T.P. terminals and ground as for the head azimuth adjustment above (and as shown in Fig. 26).
2. Turn the DOLBY NR switch ON.
3. Playback the 333Hz, 0dB section of the STD-341A test tape, and adjust VR<sub>1503</sub> (L. ch) and VR<sub>1504</sub> (R. ch) on the main board to bring the meter needle to +1dB (1.12V). This adjustment must be carried out accurately since the Dolby level adjustment is dependent upon it.

### 3.2 PLAYBACK EQUALIZER

1. Leave the meters connected to the same T.P. terminals and ground as for the head azimuth adjustments above (and as shown in Fig. 26).
2. Playback the 333Hz, -20dB section of the STD-341A test tape, and read off the values indicated.
3. Then playback the 10kHz, -20dB section of the same test tape, and adjust VR<sub>701</sub> (L. ch) and VR<sub>702</sub> (R. ch) of the playback/record amplifier so that the meter values are +1.5dB higher than those read in the above step.
4. Switch the EQ switch over to the CrO<sub>2</sub> position, and repeat the above two steps. This time, however, the 10kHz signal should read -3.6 ±1dB lower than the 333Hz signal.

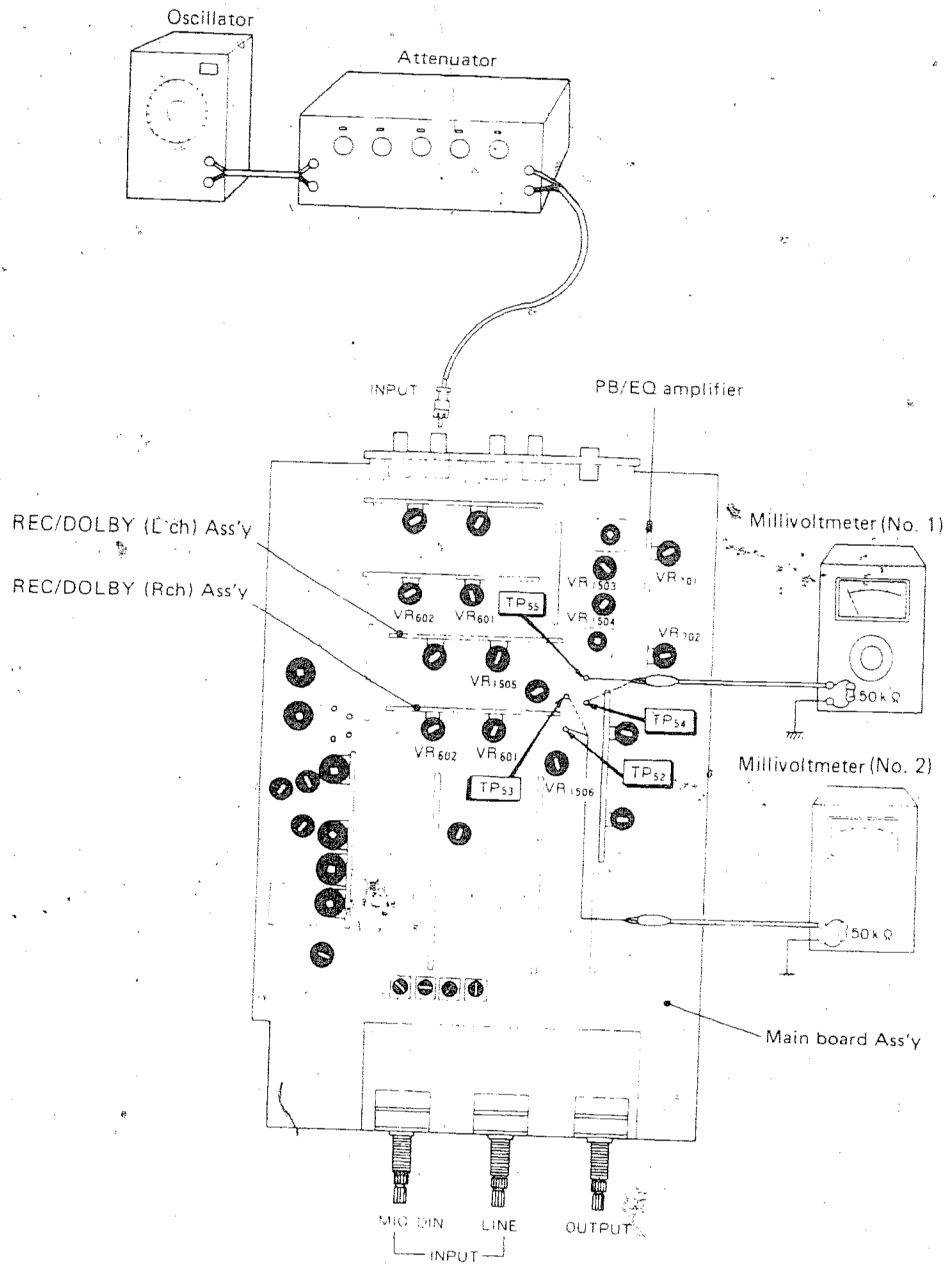

Fig. 26

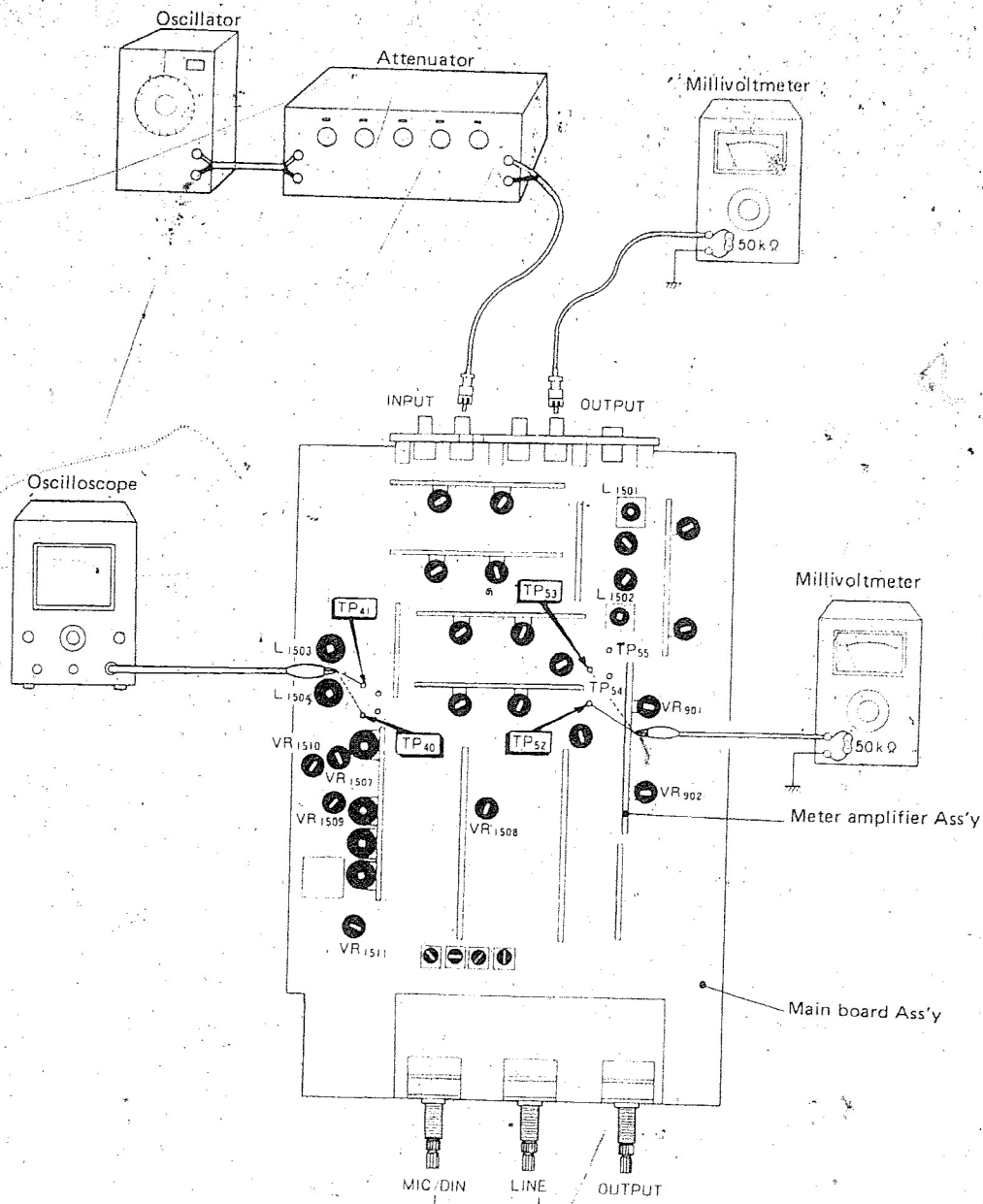

Fig. 27

### 3.4 0dB OF LEVEL METERS

1. Connect meters to the T.P. terminals No.53 (L. ch) and No.52 (R. ch) of the main board as shown in Fig. 27. Also connect both meters to ground.
2. Switch the DOLBY NR switch ON, and the MONITOR switch to SOURCE.
3. Apply the 333Hz, -10dBv (316mV) signal to the input, and adjust the line VR so that the meters read -3dBv (708mV).
4. Then adjust VR<sub>901</sub> (L. ch) and VR<sub>902</sub> (R. ch) of the meter amplifier so that the unit's level meters both read 0dB.

#### • Checking Accuracy of Level Meter Scales

1. Turn the MONITOR switch to the SOURCE position, and apply the 333Hz, -10dBv (316mV) signal to the input terminals. Then adjust the line VR so that both level meters read 0dB.
2. Then apply +4dB (-6dBv = 501mV) and -20dB (-30dBv = 31.6mV) signals to the input terminals in turn, and check that both left and right level meters read +4 ± 0.5dB and -20 ± 2dB for the respective input signals.

### 3.5 BIAS TRAP

1. Connect oscilloscopes to T.P. terminals No.40 (L. ch) and No.41 (R. ch) on the main board as shown in Fig. 27.
2. Switch the EQ switch to CrO<sub>2</sub>, and the MONITOR switch to TAPE.
3. Load an unrecorded cassette tape in the cassette compartment, and record and playback with no signals.
4. Adjust L<sub>1503</sub> (L. ch) and L<sub>1504</sub> (R. ch) on the main board to minimize the bias leak waveforms displayed on the oscilloscope screen.
5. Next, connect meters to both output VRs, and adjust L<sub>1501</sub> (L. ch) and L<sub>1502</sub> (R. ch) to bring the bias leak level to below -40dBv (10mV).
6. It is important to be accurate in this bias trap adjustment because of the effect it has on the record/playback frequency response when the DOLBY NR switch is ON.

### 3.6 RECORDING BIAS

1. Apply the 333Hz, -10dBv (316mV) signal to the input terminals. Connect a meter to the output terminals, and adjust the line volume control so that the voltage reads -7dBv (447mV) (see Fig. 27).

2. Using the STD-601 test tape, record and playback the 333Hz signal simultaneously. Adjust the playback output level to a value 0.5dB past the maximum by turning VR<sub>1509</sub> (L. ch) and VR<sub>1510</sub> (R. ch) in a clockwise direction (starting from an extreme counter-clockwise position) (See Fig. 28).
3. Since VR<sub>1509</sub> and VR<sub>1510</sub> affect each other, repeat this procedure several times.

### 3.7 RECORDING LEVEL

#### NOTE:

- The recording level adjustment must be performed accurately because of its importance in setting the Dolby level.

1. Turn the DOLBY NR switch ON, and set the DOLBY CAL control to the center position. Then apply the 333Hz, -10dBv (316mV) signal to the line input terminals.
2. Next connect a pair of meters to T.P. terminals No.53 (L. ch) and No.52 (R. ch) on the main board, and another pair of meters to the T.P. terminals No.54 (L. ch) and No.55 (R. ch), connecting all the meters to ground. (see Fig. 26).
3. Adjust the line VR so that the voltages read -3dBv (708mV).
4. Record the 333Hz signal on the STD-601 test tape.
5. Then adjust VR<sub>1505</sub> (L. ch) and VR<sub>1506</sub> (R. ch) on the main board so that the reading on the second pair of meters (connected to T.P. terminals Nos.54 & 55) comes to -3dBv (708mV).

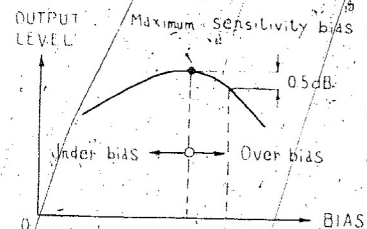

Fig. 28

### 3.8 RECORDING AND PLAYBACK FREQUENCY RESPONSE

1. Connect a meter to the line output terminals, and then apply a 333Hz, -30dBv (31.6mV) signal to the input terminals (see Fig. 27).
2. Turn the MONITOR switch to the SOURCE position.
3. Adjust the line VR until the voltage reads -27dBv (44.67mV).
4. Record the 333Hz signal on the STD-601 test tape, and turn the MONITOR switch to the TAPE position.
5. Next, record and monitor the 10kHz signal simultaneously, and adjust VR<sub>1508</sub> (L. ch) and VR<sub>1508</sub> (R. ch) until the playback output level deviation is +0.5dB in respect to the 333Hz signal.
6. Check that the record and playback frequency responses satisfy those shown in Fig. 29.
7. If the frequency responses lie outside the rated values, repeat the recording bias adjustment (see section 3.6), employing values in the +0.2 to +0.7 range past the maximum sensitivity bias.

#### • Recording and Playback Frequency Response with Chrome Tape

1. Switch the EQ switch to CrO<sub>2</sub>.
2. Record and monitor the 333Hz, -30dBv (31.6mV) signal on the STD-602 test tape simultaneously. Following the same procedure as before, next apply the 10kHz signal, and adjust VR<sub>1511</sub> on the main board until the 10kHz deviation is +0.5dB in respect to the 333Hz signal.
3. If this adjustment procedure does not succeed, repeat the adjustment of VR<sub>1511</sub> until the deviation is within +0.5 ± 0.5 dB.

#### NOTE

Since the recording bias and recording level adjustments have an affect upon each other, be sure to repeat the recording level adjustment if the recording bias is readjusted.

#### • Recording and Playback Frequency Response with Fe-Cr Tape

Set the EQ switch to Fe-Cr, and then record and monitor the 333Hz, -30dB (31.6mV) signal on the STD-601 test tape simultaneously. Check that the 10kHz deviation is -2.5 ± 2dB in respect to the 333Hz signal.



Overall Frequency Response

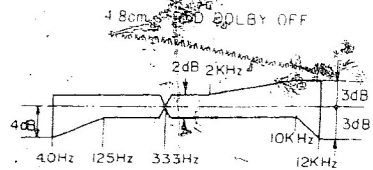

Fig. 29-A

Playback Frequency Response

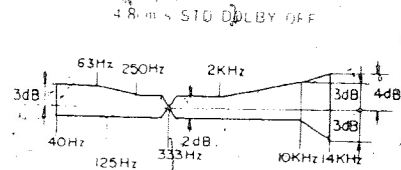

Fig. 29-E

4.8cm STD DOLBY ON

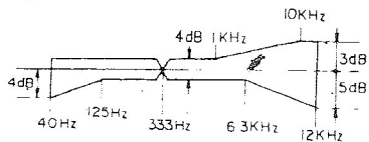

Fig. 29-B

4.8cm CHROME DOLBY OFF

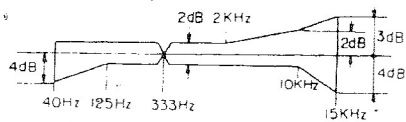

Fig. 29-C

4.8cm CHROME DOLBY ON

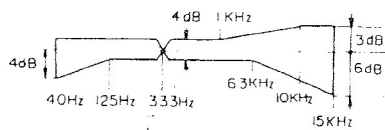

Fig. 29-D

### 3.9 PLAYBACK DOLBY

1. Connect up measuring equipment as shown in Fig. 30.
2. Turn the DOLBY NR switch ON, and then turn the  $VR_{601}$  in the Playback Dolby Assembly up to maximum level.
3. Adjust the oscillator output so that the tester indicates 0dBv (1V). The frequency is set to 50kHz.
4. With the input level 30dB lower than the value in the above step, adjust  $VR_{602}$  (also in the Playback Dolby Assembly) so that the voltage reads -40dBv (10mV).
5. Readjust the input level again to a level 22dB lower than that in step No.3 above, and adjust  $VR_{601}$  a second time so that the voltage reads -30dBv (31.6mV).

### 3.10 RECORDING DOLBY

1. Connect meters to TP terminals No.52 (R. ch) and No.53 (L. ch) on the main board (Fig. 26).
2. Turn the DOLBY NR switch ON, and then turn  $VR_{601}$  in the Recording Dolby Assembly up to maximum level.
3. Apply the 5kHz, -10dBv (316mV) signal to the input terminals, and adjust the line VR so that the voltage reads 0dBv (1V).
4. Next lower the input level 40dB below the level used in the above step, and adjust the Recording Dolby Assembly  $VR_{602}$  so that the voltage reads -30dBv (31.6mV).
5. Then readjust the input level to 20dB below the level used in step 3 above. This time adjust  $VR_{601}$  so that the voltage reads -22dBv (79.4mV).

### 3.11 PEAK INDICATOR OPERATION

1. Connect a meter to the output terminals, and apply a 333Hz, -10dBv (316mV) signal to the input terminals. (See Fig. 27).
2. Set the MONITOR switch to the SOURCE position, and press the REC button.
3. Rotate the left channel line VR and check that the peak indicator lights up when the meter reads -2dBv (794mV)  $\pm 1$ dB. During this step, keep the right channel VR at minimum level.
4. Now repeat the above step with the right channel.

### 3.12 LIMITER OPERATION

1. Connect a voltmeter to the output terminals, and apply the 333Hz, -10dBv (316mV) signal to the input terminals (see Fig. 27).
2. Set the MONITOR switch to SOURCE.
3. Adjust the line VR so that the meter reads -7dBv (447mV).
4. Then raise the input level by 20dB, and check that the meter reads -2dBv (794mV)  $\pm 1.5$ dB when the LIMITER switch is ON.

### 3.13 DOLBY RECORDING CALIBRATION

1. Turn the TEST TONE switch ON, and the MONITOR switch to the SOURCE position.
2. Rotate the LINE VR so that the VU meters read 0VU.
3. Then record the test tone onto the STD-601 test tape, and set the MONITOR switch to the TAPE position.
4. Check that the VU meter needles deflect at this time by less than  $\pm 1$ dB from the position set in step 2 above (with DOLBY REC CAL VR at the center click stop).
5. Finally turn the DOLBY REC CAL VR in both the clockwise and anticlockwise directions from the center click stop, and check that the VU meter needles deflect from the position shown in step 4 by more than  $\pm 2.5$ dB when turned clockwise, and by more than -3.5dB when turned in the anticlockwise direction.

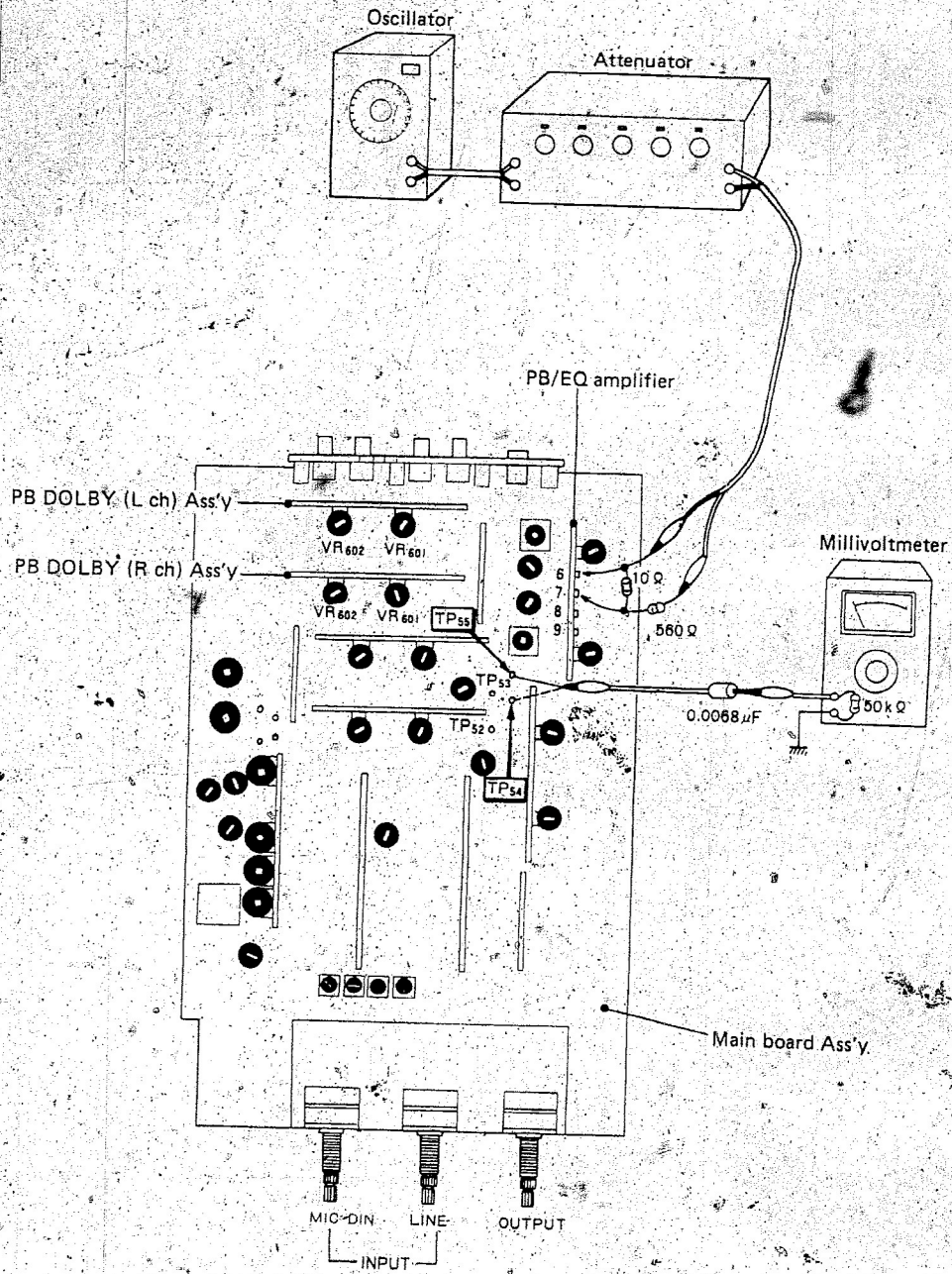

Fig. 30